

**MERCEDES BENZ SPRINTER RWD (907)
2.0L OM654 Euro 6 / 6.2 / 6d-Temp (+N62)**

CODE / CODICE: 0500.1662

ALTERNATOR / GENERATOR

NATIONS N62 ALTERNATOR
WITH Ø 49MM PULLEY

FITTING INSTRUCTIONS

EINBAUANLEITUNGEN
INSTRUCTIONS POUR LE MONTAGE
ISTRUZIONI DI MONTAGGIO
INSTRUCCIONES DE MONTAJE

Contents

ENGLISH	4
Standard Fastener Torque Values	4
Foreword	4
Kit Details	5
Vehicle Details	5
Parts View.....	6
Parts List	7
Pre Installation.....	8
Removal of Parts.....	8
Mount Bracket Installation	8
Alternator Installation.....	10
Finish	11

STANDARD FASTENER TORQUE VALUES

In the absence of specific torque values detailed in this fitting instruction manual, the following chart can be used as a guide to the maximum safe torque for specific size and grade of fastener.

VALORES ESTÁNDAR DE LOS PARES DE APRIETE Y FIJACIÓN

En ausencia de valores para los pares de apriete específicos detallados en este manual de instrucciones de montaje, se puede utilizar la siguiente tabla como guía para consultar el máximo par de torsión seguro para un tamaño concreto y su grado de fijación.

Caution: Measures must be followed accurately to steer clear of the possibility of damage to individuals
Warning: This calls awareness to actions which must be pursued to avoid damage to the components.
NB: This calls awareness to make the job easier or gives useful information.

STRENGTH	4.8		8.8		10.9		12.9	
	Max Torque		Max Torque		Max Torque		Max Torque	
Dia / Pitch	lb.ft	Nm	lb.ft	Nm	lb.ft	Nm	lb.ft	Nm
M5 x 0.80	2	3	4.5	6	6.5	9	7.5	10
M6 x 1.00	4	5.5	7.5	10	11	15	13	18
M8 x 1.25	10	13	18	25	26	35	33	45
M10 x 1.25	20	27	39	53	57	78	66	90
M10 x 1.50	18	25	37	50	55	73	63	86
M12 x 1.75	33	45	63	85	97	130	111	150
M14 x 2.00	55	75	103	140	151	205	177	240
M16 x 2.00	85	115	159	215	232	315	273	370

FOREWORD

The purpose of this manual is to facilitate the installation of an Auxiliary Alternator / Generator .The information given is merely instructive, should any complications arise contact the Technical department. The manufacturer's warranty does not cover any problems caused by defective installation or alterations made unless authorised. The manufacturer shall not be responsible for any injury, damage or loss caused directly or indirectly as a result of using this manual or the information contained within it.

1 SAFETY MEASURES:

Before fitting the Compressor adapter drive kit, ensure the following for damage:

- a Inner and outer trim and body work
- b Engine idle pace
- c Check all the vehicle functions

Check list:

- a Ensure that the right kit has been selected
- b Before installing, check that all the correct pieces are present; also ensure that there are no missing or broken pieces
- c When fitting, make sure the vehicle is properly protected against damage.

Installation apparatus

- a Calibrated torque wrench
- b Hand service tools
- c Protective covers and shields

2 PRECAUTIONS

- a Detach the battery negative lead.
- b Torque all bolts where stated using a calibrated torque wrench.
- c Take extreme care with moving parts.
- d Remove the vehicle's ignition key and keep it with you.
- e Wear safeguards and make sure that liquid refrigerant never touches your skin

NOTES

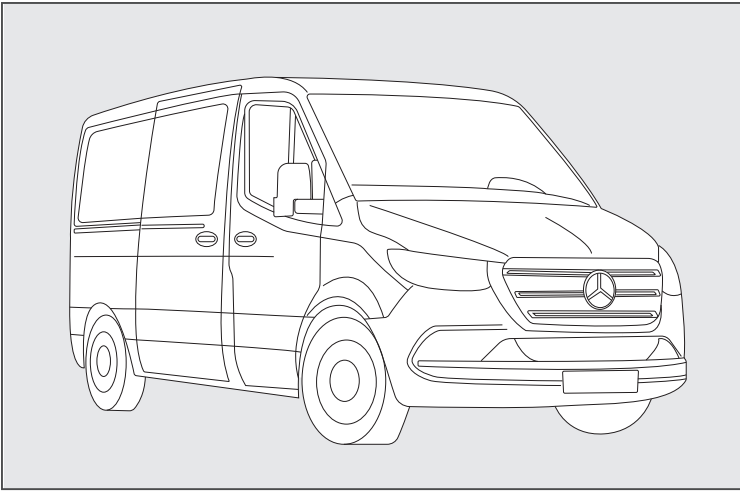

VEHICLE DETAILS

Manufacturer	Mercedes Benz
Make	Sprinter
Model	RWD (907)
Engine Details kW/PS	84 (114), 110 (150), 125 (170)
Engine cc	1950
Chassis Nos.	N/A
LHD	YES
RHD	YES
PAS	YES
A/C	YES / NO
Voltage	12v

KIT DETAILS

Kit Part Number	0500.1662
Description	Auxiliary Alternator / Generator Mount Kit
Drive Ratio	0.29:1 with Ø49mm pulley
Fitting Time	60 Minutes
Belt Type	6PK 1165
Belt Part Number	0820.1012
Note:	Vehicles with N62 option

PARTS LIST / LISTA DE PIEZAS

ITEM	CODE / CODICE / KODE / CODIGO	DESCRIPTION / DESCRIZIONE / BESCHREIBUNG / DESCRIPCION	QTY.	COMMENTS
1	0441.6351	AMB Assy Mercedes OM654	1	-
2	1705.5061	Automatic Belt Tensioner	1	-
3	1700.5161	Idle Pulley 54mm	1	-
4	1700.0541	Idle Pulley - 69 x 26.5 6PK	1	-
5	2704.6031	Centering Pulley Bolt M8 x 32 : 1.25 -10.9	2	-
6	0706.0041	Pulley Cap	2	-
7	2704.6071	Hexagon Flange Bolt - M8 x 20 : 1.25 - 10.9	5	-
8	2803.6751	Spacer OD19 ID8.5 L21.5	1	-
9	2803.8511	Spacer - 23 OD x 17.0 ID x 12.5 L	1	-
10	2803.7791	Pulley Nut M8 - Low Head 22 A/F	1	-
11	2809.0011	Washer M10 Flat DIN 125 - A 10.5	2	-
12	2735.0071	Durlok Hexagon Flange Nut - M10 : 1.50	1	-
13	2704.0601	Socket Head Cap Screw - M8 x 65 : 1.25 - 10.9	1	-
14	2704.0201	Hexagon Flange Bolt Durlok - M8 x 40 : 1.25 - 12.9	4	-
15	2704.5971	Hexagon Flange Bolt - M8 x 55 : 1.25 - 10.9	1	-
16	2705.5101	Hexagon Socket Head Cap Screw M10 x 110 : 1.50 - 12.9	2	-
17	2803.8631	Spacer - 24.0 OD x 10.5 ID x 18.65 L	1	-
18	3021.0581	GMK Upper Mnt- OM654	1	-
19	3021.0591	GMK Rear Mnt- OM654	1	-
20	2803.8541	Spacer - 24.0 OD x 10.5 ID x 10.2 L	2	-
21	0820.1012	Belt - Poly Groove 6PK 1165	1	-

PRE-INSTALLATION

Note: Prior to commencing work, please examine the instructions with care. The alphabetical symbols on the diagram relate to written instructions, numerical symbols relate to the parts listing.

REMOVAL OF PARTS

1. Remove and discard OE bracket (A) & 4x retaining bolts (B) - Fig 1

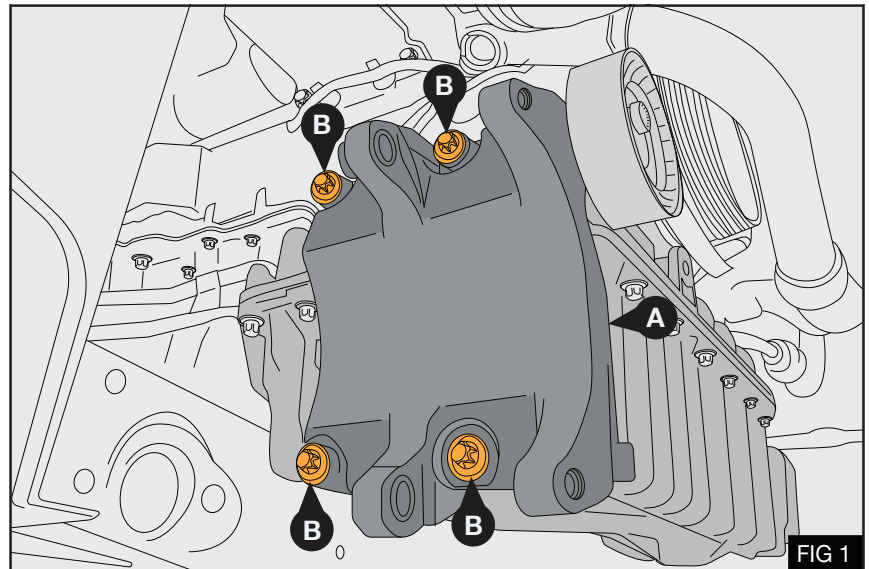
**MOUNT BRACKET INSTALLATION**

WARNING: Do not use Thread Lock unless instructed to do so.

1. Fit supplied bracket (1) to oil pan using 4x M8 x 40 bolts (14) - Fig 2
 - Torque bolts (14) to 22 lb.ft / 30 Nm

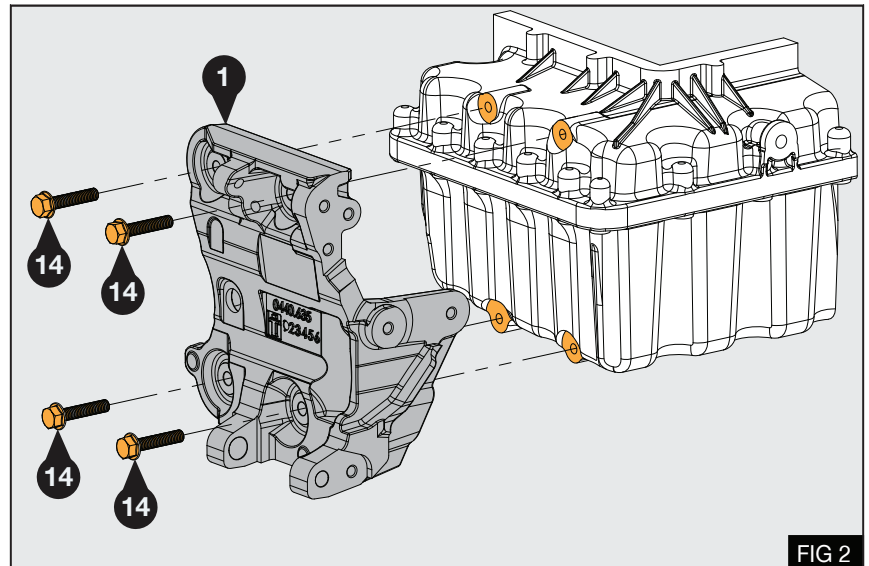

2. Install upper mount plate (18) to bracket (1) using 3x M8 x 20 bolts (7) - Fig 3
 - Torque bolts (7) to 22 lb.ft / 30 Nm

Note: The idle pulley (3) securing bolt (5) is designed to fit into the pulley from one direction only. The metal behind the bearing shield on the rear of the bearing should face the upper mount plate.

3. Assemble idle pulley (3) onto the upper mount plate (18) using spacer (9) and threaded insert (10)
 - Torque pulley bolt (5) to 22 lb.ft / 30 Nm
4. Fit pulley cap (6)

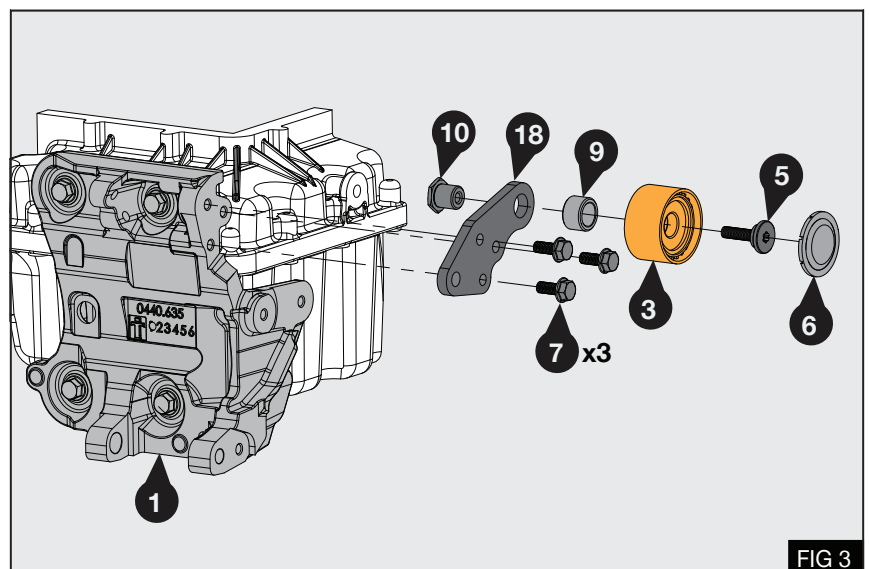

5. Install the rear mount plate (19) to bracket (1) using 2x M8 x 20 bolts (7) - Fig 4

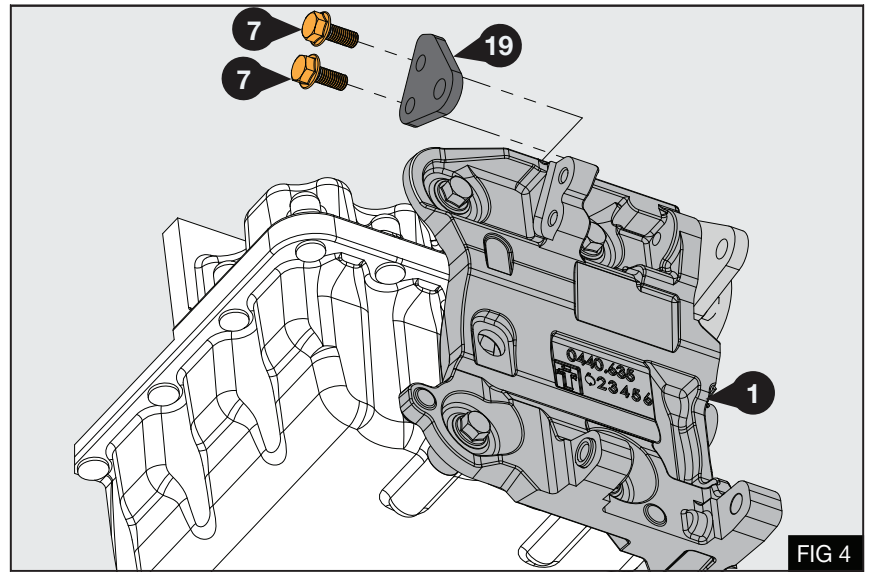

FIG 4

6. Install idle pulley (4) to bracket (1) using bolt (5) - Fig 5

- Torque bolt (5) to 22 lb.ft / 30 Nm

7. Fit pulley cap (6)

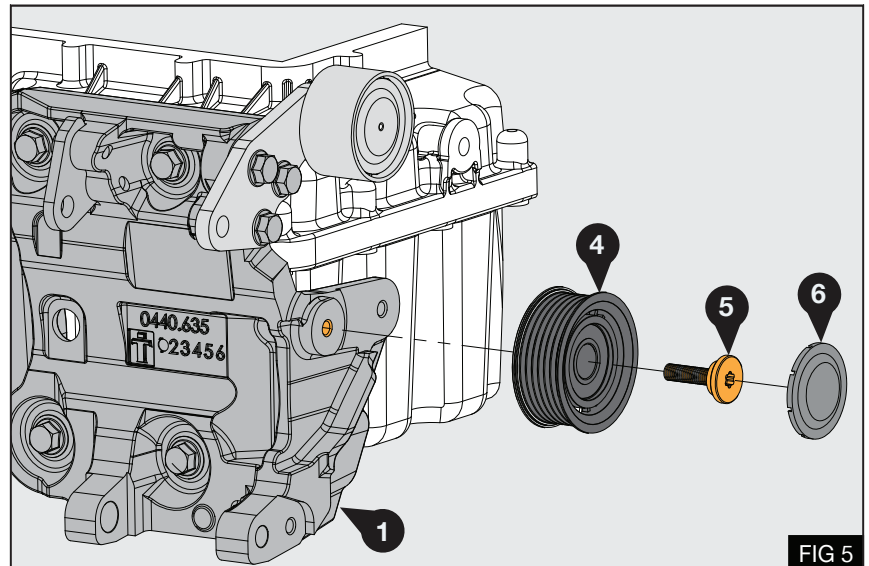

FIG 5

8. Install the automatic tensioner (2) to bracket (1) using spacer (8), with M8 x 55 bolt (15). Install the M8 x 65 socket head cap (13) as indicated - Fig 6

- Torque bolt (13) to 20.3 ± 1.6 ft / 27.5 ± 2.2 Nm
- Torque bolt (15) to 22 lb.ft / 30 Nm

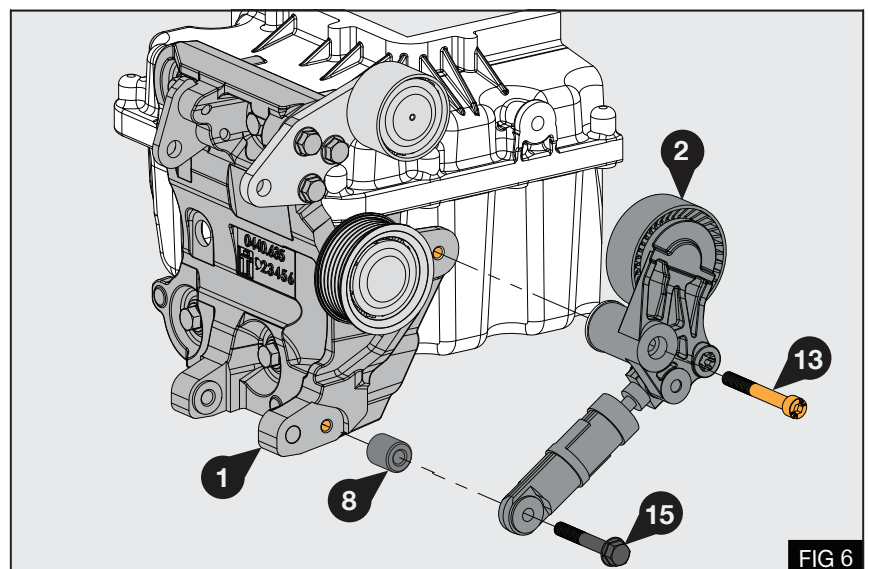

FIG 6

ALTERNATOR INSTALLATION

1. Before continuing, check your alternator matches the key specifications in Fig 7
 - If the alternator does not match the specifications, you may need an alternative mounting kit or alternator build. In this situation, please contact your vendor.
 - Incorrect application may damage components!

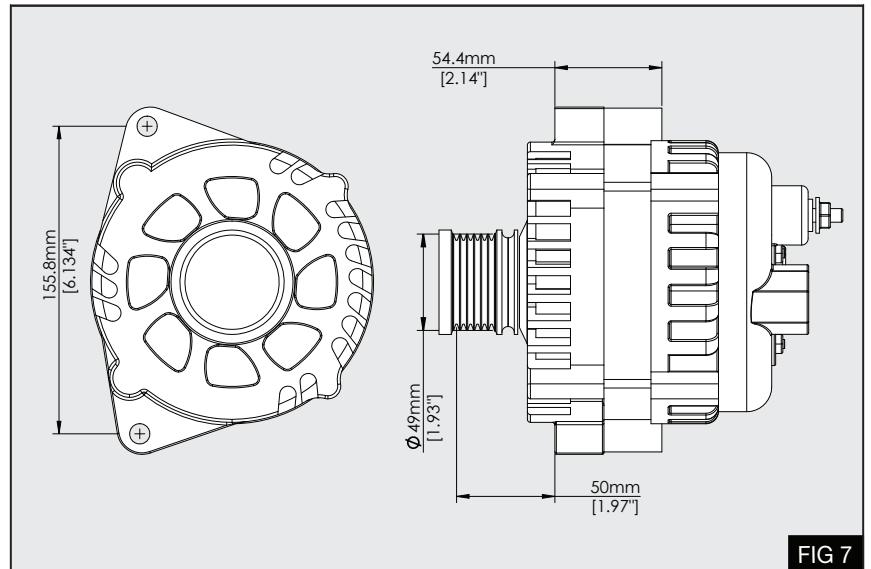

FIG 7

2. Install the alternator using 2x M10 x 110 bolts (16) with washers (11) while inserting spacers (20) between the alternator front faces and the mount / plate. - Fig 8
3. Fit the spacer (17) at the rear upper position and secure bolt (16a) with M10 nut (12) once through the rear plate.
4. The lower bolt (16b) engages into the threaded bush fitted into the mount. - Fig 8

Note: The lower mount bush will move toward the alternator and eliminate any clearance as it is tightened.

Follow the torque tightening sequence:

- 2x M8 x 20 bolts (7) - 22 lb ft / 30 Nm
 - M10 x 110 bolt (16a) - 37 lb ft / 50 Nm
 - M10 x 110 bolt (16b) - 37 lb ft / 50 Nm
5. Before installing the drive belt (21) cycle the automatic tensioner (2) through its full travel a minimum of three times - Fig 9

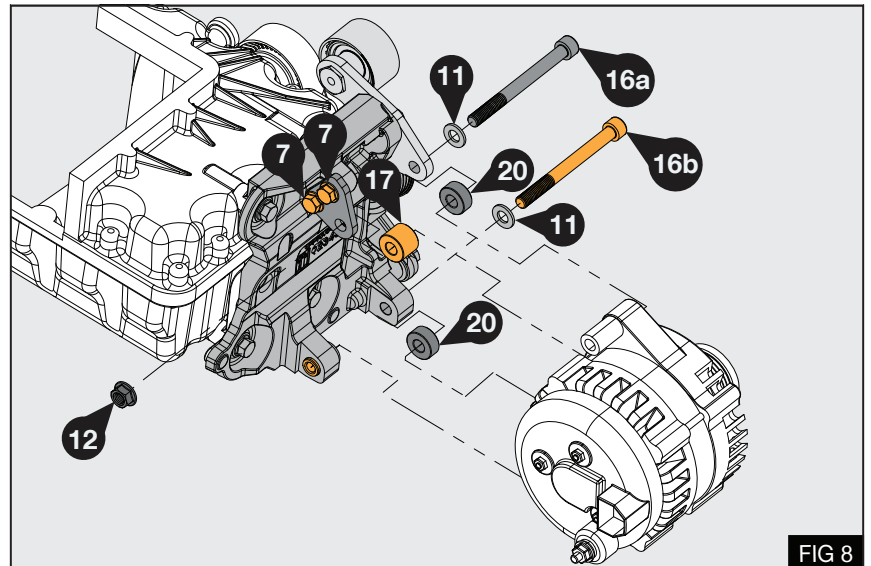

FIG 8

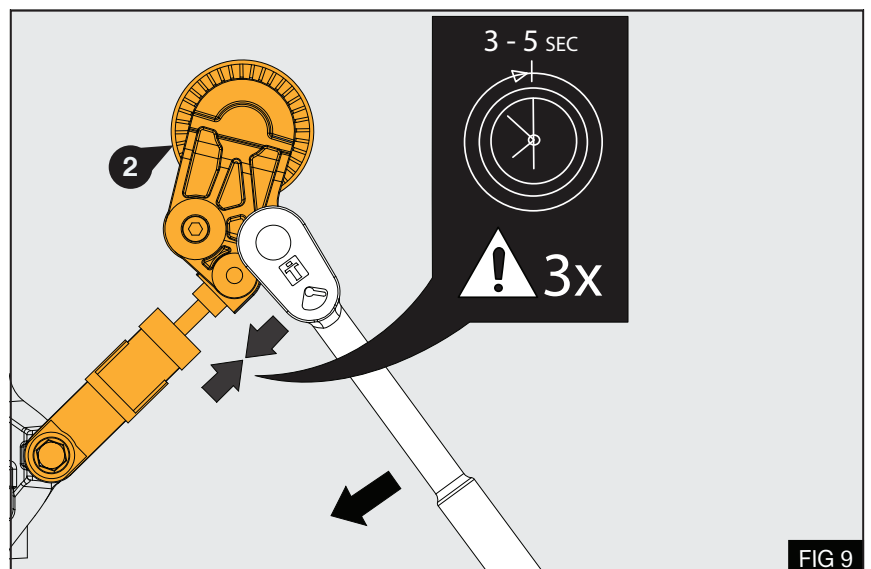
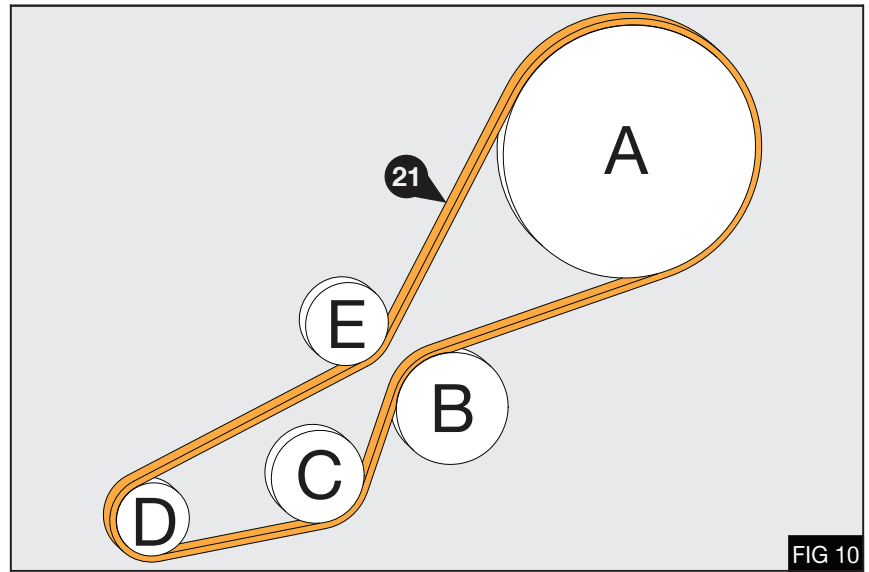

FIG 9

6. Install the drive belt (21) as shown - Fig 10

- A Crankshaft Pulley
- B Automatic Tensioner
- C Idle Pulley
- D Alternator
- E Idle Pulley

Note: Fit drive belt (21) over automatic tensioner (B) last.



FINISH

1. Before starting the engine check all the installed parts and ensure that the belts are installed correctly. Run the unit for at least ten minutes, then check the whole mounting assembly.
2. Check clearances between hoses, wiring and kit components

(EN)

Techni focuses on constant upgrading of its products. The Manufacturer reserves the right to modify the models and components described in the present publication at any time for technical or commercial reasons and without prior notice. For further information, contact Techni technical services.

(ES)

Techni aspira a un constante mejoramiento de su producción. La Fábrica se reserva el derecho de aportar en cualquier momento y sin preaviso modificaciones a los modelos y los componentes descritos en esta publicación por razones técnicas o comerciales. Para ulteriores informaciones dirigirse al servicio asistencia Techni.

SALES AND SERVICE
VENTAS Y SERVICIO

Techni

ENGINEERING SOLUTIONS

Techni US LLC

6101 Guion Road,
Indianapolis, Indiana, 46254
Telephone: (+1) 317 672 3364
Fax: (+1) 317 755 0418
Email: sales@techni.us

Techni UK Ltd

Sundorne Trade Park, Henley Way,
Shrewsbury, United Kingdom, SY1 4NS
Telephone: (+44) (0) 1743 443176
Email: sales@techni.co.uk

Techni EU SL

Pol. Ind. Nueva Campana,
Nave 46a, Marbella, Malaga, 29660, Spain
Telephone: (+34) 952 789 142
Email: sales@technies.com